

YK500XC

Clean type: Medium type



- Arm length 500mm
- Maximum payload 10kg

Ordering method

YK500XC			RCX340-4							
Model	Z axis stroke	Cable length	Controller / Number of controllable axes	Safety standard	Option A (OP.A)	Option B (OP.B)	Option C (OP.C)	Option D (OP.D)	Option E (OP.E)	Absolute battery
	200: 200mm 300: 300mm	3L: 3.5m 5L: 5m 10L: 10m								

Specify various controller setting items. RCX340 ▶ **P.678**

Basic specifications

	X axis	Y axis	Z axis	R axis
Axis specifications				
Arm length (mm)	250	250	200 300	-
Rotation angle (°)	+/-120	+/-142	-	+/-180
AC servo motor output (W)	400	200	200	100
Repeatability ^{Note 1} (XYZ: mm) (R: °)	+/-0.02		+/-0.01	+/-0.005
Maximum speed (XYZ: m/sec) (R: °/sec)	4.9		1.7	876
Maximum payload (kg)	10			
Standard cycle time: with 2kg payload (sec)	0.53			
R-axis tolerable moment of inertia ^{Note 2} (kgm ²)	0.12			
User wiring (sq x wires)	0.2 x 20			
User tubing (Outer diameter)	φ6 x 3			
Travel limit	1.Soft limit, 2.Mechanical stopper (X, Y, Z axes)			
Robot cable length (m)	Standard: 3.5 Option: 5, 10			
Weight (kg)	31			
Degree of cleanliness	CLASS 10 ^{Note 3}			
Intake air (Nl/min)	60 ^{Note 4}			

Note 1. This is the value at a constant ambient temperature. (X,Y axes)
 Note 2. The acceleration coefficient is set automatically in accordance with the tip weight and R-axis moment of inertia settings.
 Note 3. Per 1cf (0.1μm base), when suction blower is used.
 Note 4. The necessary intake amount varies depending on the use conditions and environment.

Controller

Controller	Power capacity (VA)	Operation method
RCX340	1500	Programming / I/O point trace / Remote command / Operation using RS-232C communication

Note. The movement range can be limited by changing the positions of X and Y axis mechanical stoppers. (The movement range is set to the maximum at the time of shipment.)
 See our robot manuals (installation manuals) for detailed information.

Our robot manuals (installation manuals) can be downloaded from our website at the address below:
<https://global.yamaha-motor.com/business/robot/>

YK500XC

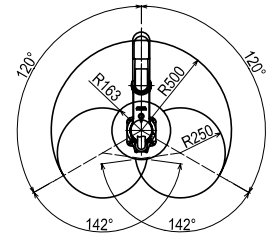
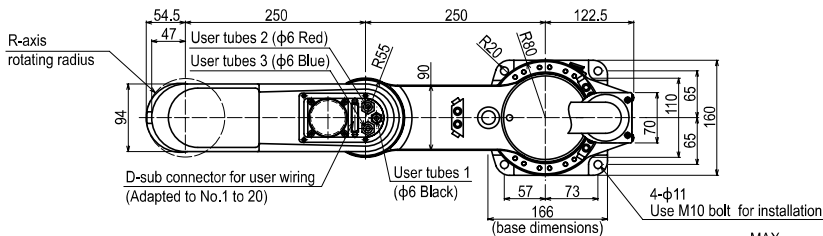

Working envelope

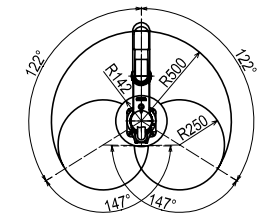

X,Y axis mechanical stopper position

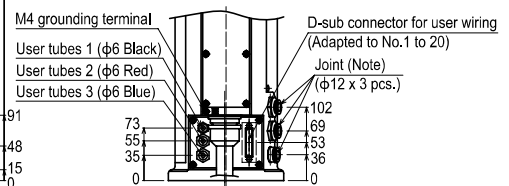
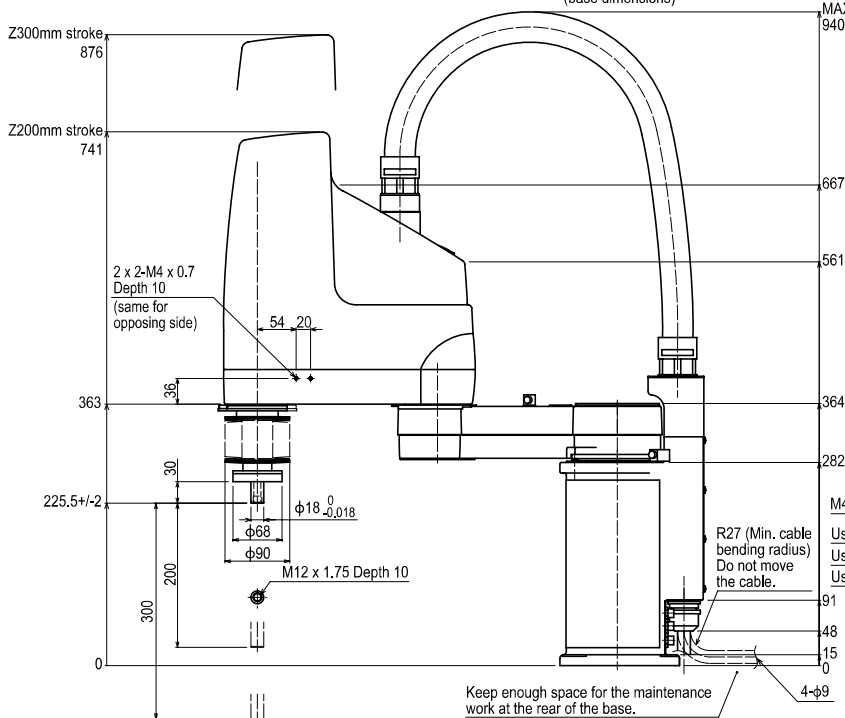

Note: For details about tubing work, refer to the User's Manual.